



# JACK KNIGHT

Developments

## PRESS RELEASE

**Jack Knight Developments** working in association with **Bell Performance** are proud to announce the availability of The New Renault Transaxle UN1 Gearbox Upgrade Kit. This Kit incorporates a newly strengthened one piece Primary shaft with close ratio straight cut 1st gear and semi-helical 2nd gear, all made using high strength aerospace quality materials. This upgrade eliminates the main weaknesses of the UN1/369 type transmissions enabling higher power and torque to be handled, especially in the vulnerable overhung 5th gear. It is easy to fit the upgrade for the many vehicles that used the UN1 family of gearboxes such as the Lotus Esprit and various replica cars, and enables the gearbox to handle the high outputs that large capacity and turbocharged V8's can produce.

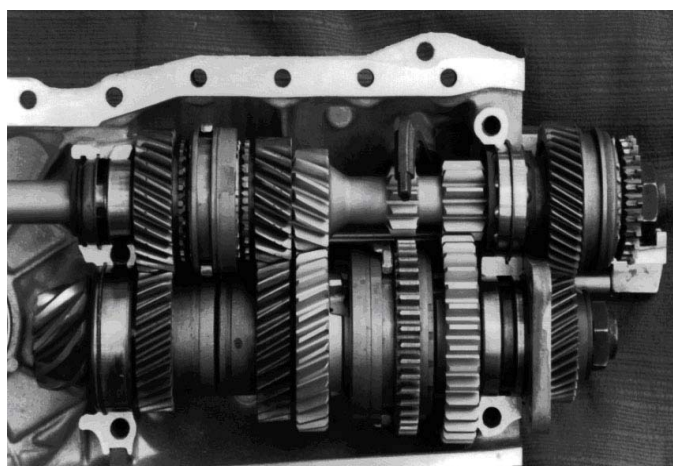
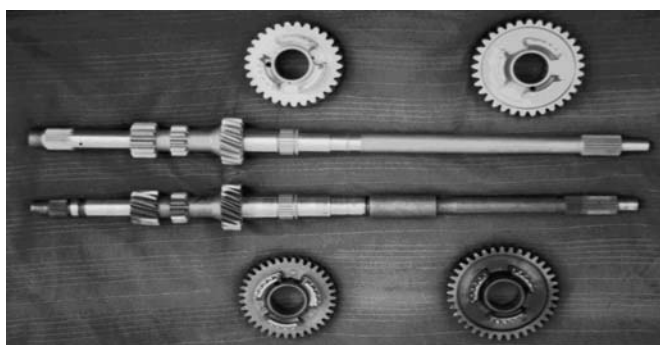

The picture above shows the upgrade kit fitted in place with the New 1st and 2nd gears.

**Please note** this Upgrade Kit is offered on an **exchange basis**. In order to complete the upgrade the customer should supply the original gearbox or internals for further modification, and specify which shaft is required.

**Jack Knight Developments** have been designing and manufacturing automotive components for over 50 years. We are pleased to be able to offer owners a Stronger alternative which can easily be fitted into their current gearboxes utilising existing parts for ease and substantial cost reduction. There are two clutch spline options either Ford 1" 23 Tooth or a standard Renault 21 tooth 24 mm.

### Jack Knight Developments

Butts Road  
Woking  
Surrey  
GU21 6JX

Tel: 01483 764326

Fax: 01483 769893

Email: [info@jackknight.co.uk](mailto:info@jackknight.co.uk)

or: [sales@jackknight.co.uk](mailto:sales@jackknight.co.uk)

Web: [www.jackknight.co.uk](http://www.jackknight.co.uk)

**RENAULT UN1 TRANSAXLE GEARBOX UPGRADE KIT (LOTUS ESPRIT VERSION - FORD CLUTCH SPLINE)**

PART	PART NUMBER	DESCRIPTION	QUANTITY IN KIT
1	JKD-UN1-MS06	PRIMARY SHAFT (12/11mm/16 TEETH)	1
2	JKD-UN1-00136	STRAIGHT CUT 1ST GEAR (35 TEETH)	1
3	JKD-UN1-00229	HELICAL 2ND GEAR (29 TEETH)	1
4	JKD-UN1-BRGS06	5TH GEAR BEARING SLEEVE	1
5	JKD-UN1-R001	STAKE NUT (M22x)	1

PRICE FOR UPGRADE KIT: £1995.00 + VAT

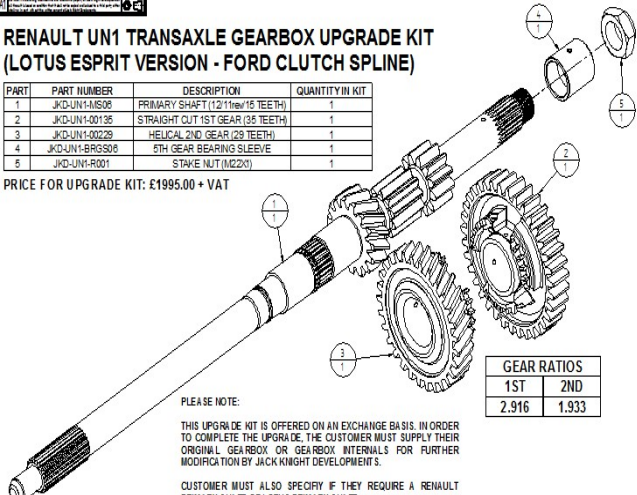

GEAR RATIOS	
1ST	2ND
2.916	1.933

**PLEASE NOTE:**  
THIS UPGRADE KIT IS OFFERED ON AN EXCHANGE BASIS. IN ORDER TO COMPLETE THE UPGRADE, THE CUSTOMER MUST SUPPLY THEIR ORIGINAL GEARBOX OR GEARBOX INTERNALS FOR FURTHER MODIFICATION BY JACK KNIGHT DEVELOPMENTS.  
CUSTOMER MUST ALSO SPECIFY IF THEY REQUIRE A RENAULT PRIMARY SHAFT OF LOTUS PRIMARY SHAFT  
CUSTOMER MUST SPECIFY WHICH CLUTCH SPLINE OPTION THEY REQUIRE:  
OPTION 1: UPGRADED FORD 23 TEETH, 1 INCH OUTSIDE DIAMETER  
OPTION 2: STANDARD RENAULT 21 TEETH, 24mm OUTSIDE DIAMETER

**JACK KNIGHT**  
Developments  
SURREY  
WOKING  
GU21 6JX  
TEL: 01483 764326  
FAX: 01483 769893  
EMAIL: [info@jackknight.co.uk](mailto:info@jackknight.co.uk)  
RENAULT UN1 UPGRADE KIT JKD-UN1-UGL1

The kit price is only £1995. A complete gearbox rebuild service is available at a cost of £375.

Soon to be released **Upgraded Synchronesh**